

§ 5 ライニング鋼管 (SGP-VA, SGP-FVA)

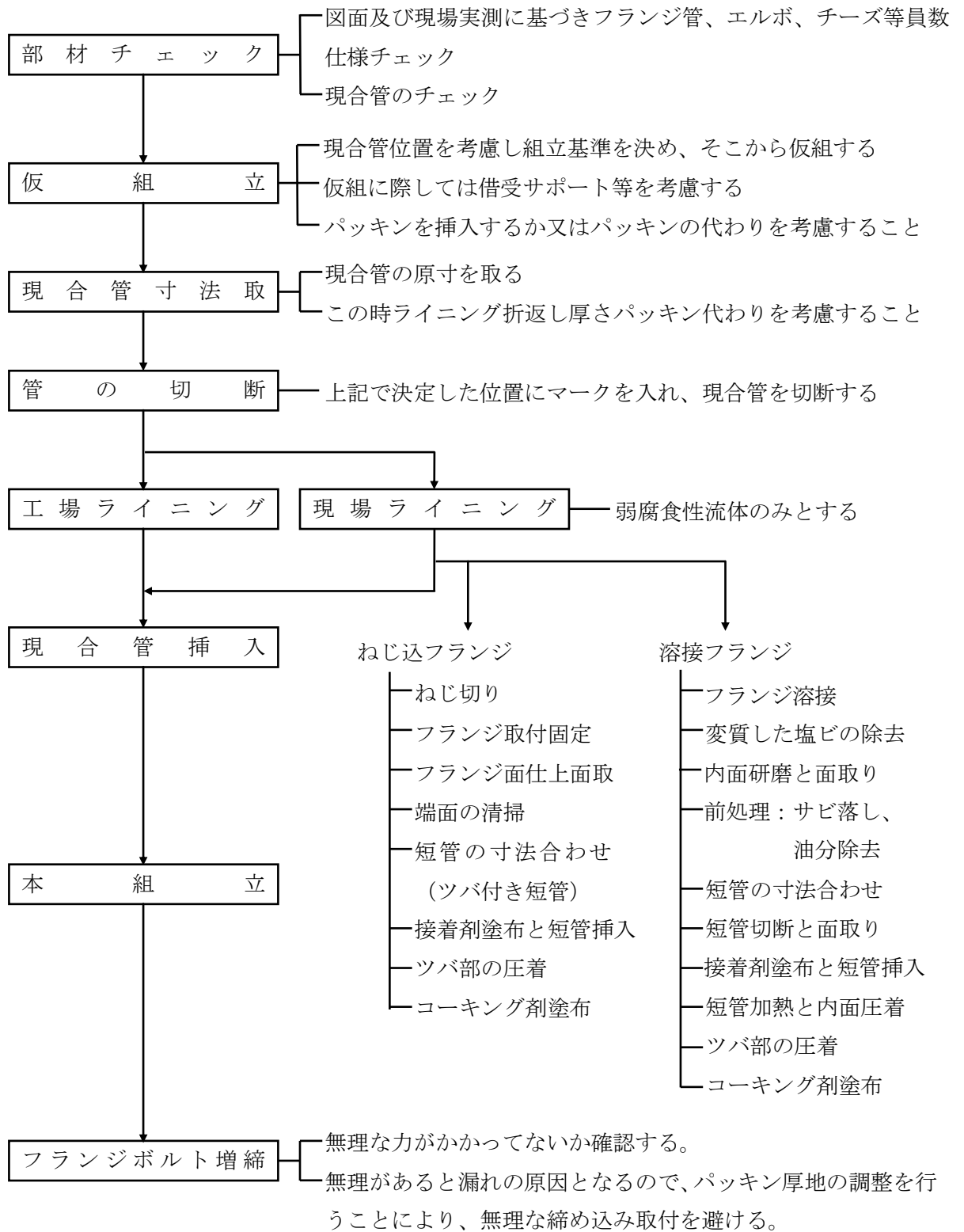

ねじ込フランジ

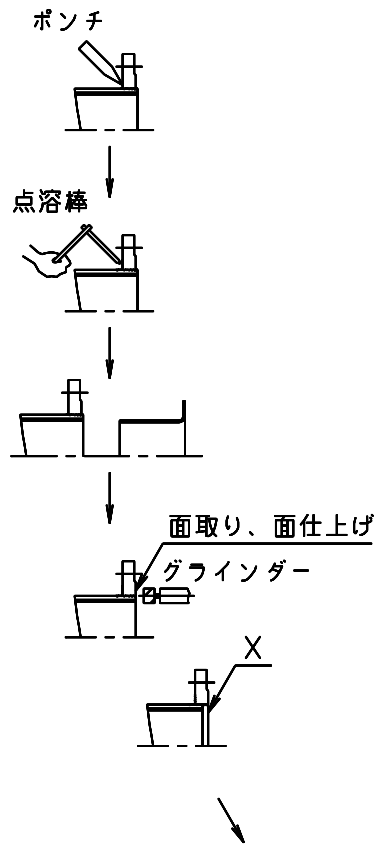

溶接フランジ



図-1 ねじ込・溶接フランジ

§ 6 ステンレス継目無管 (SUS)



スリーブ継手

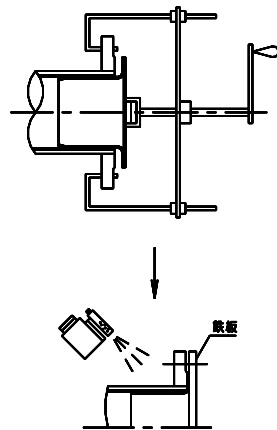
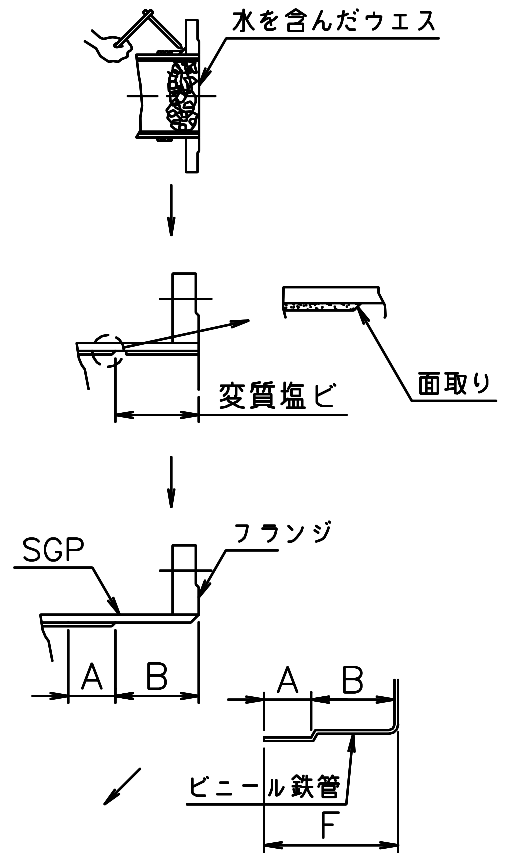
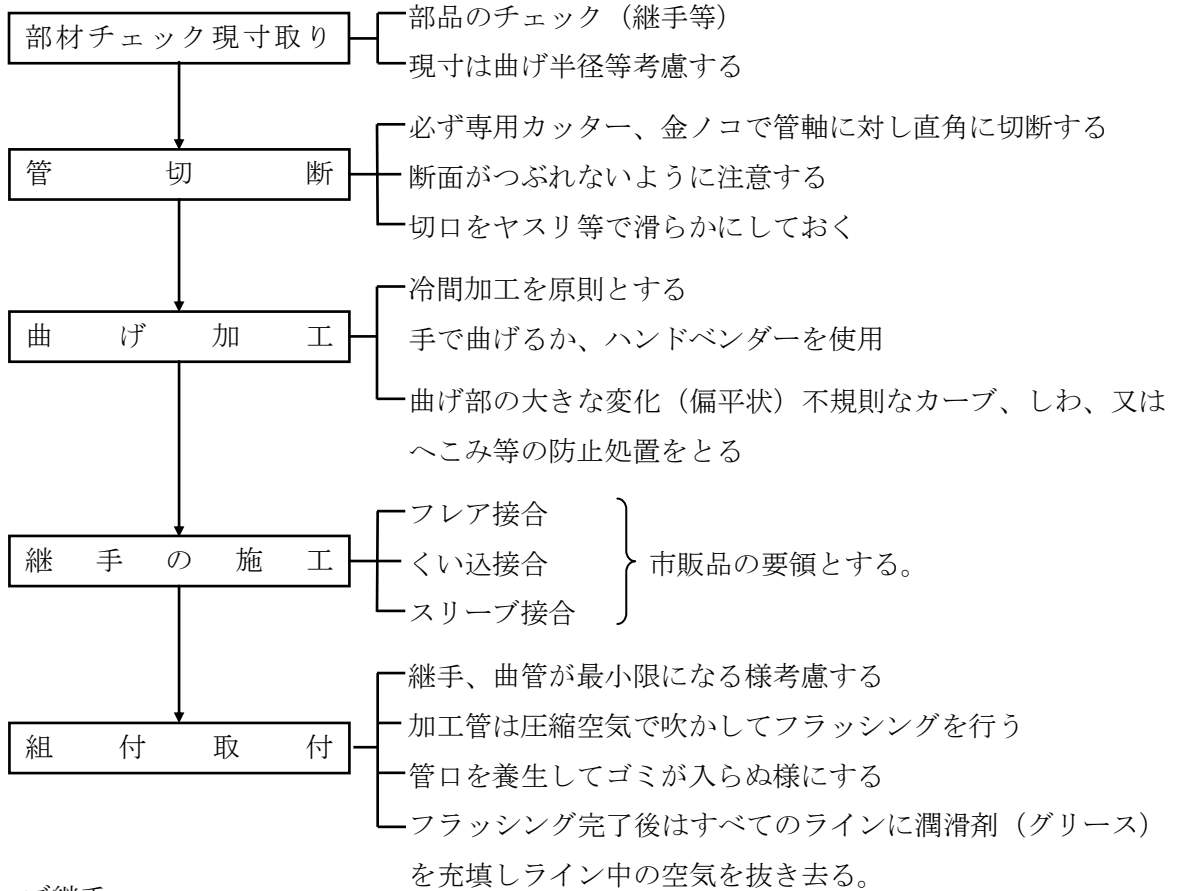
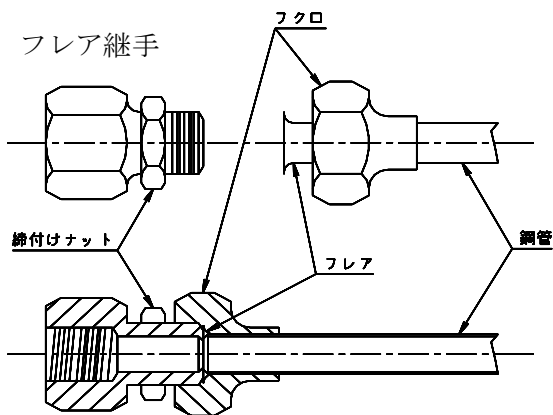
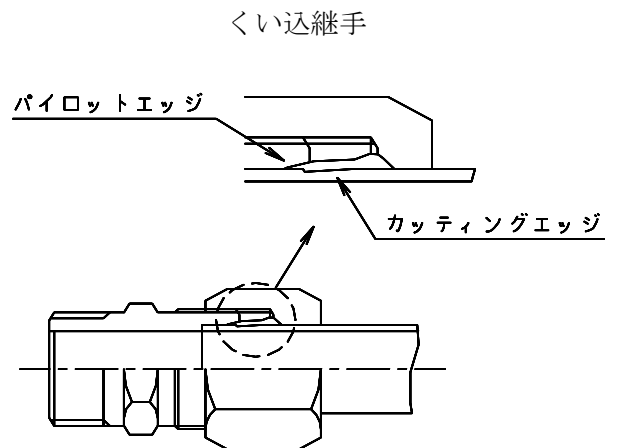
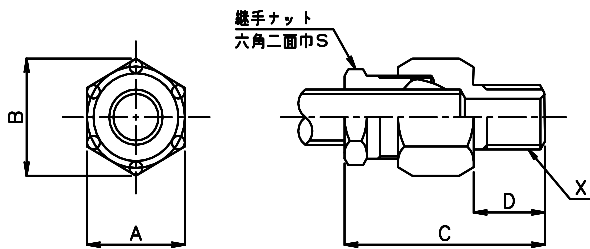

継手の例 (参考)