

南北断面図

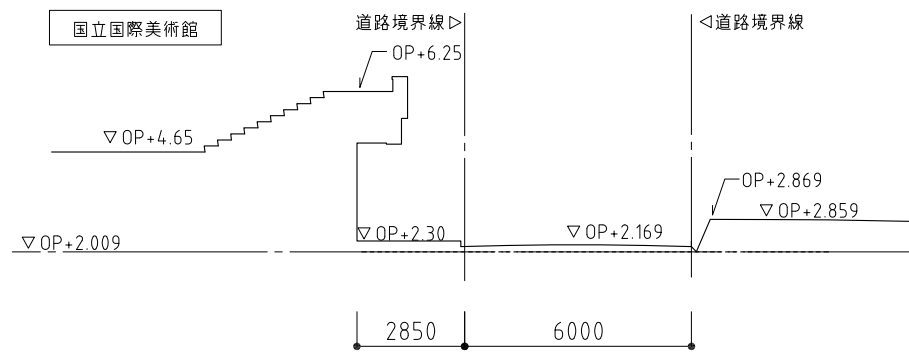

A部 1/200

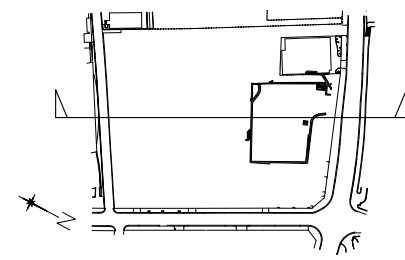
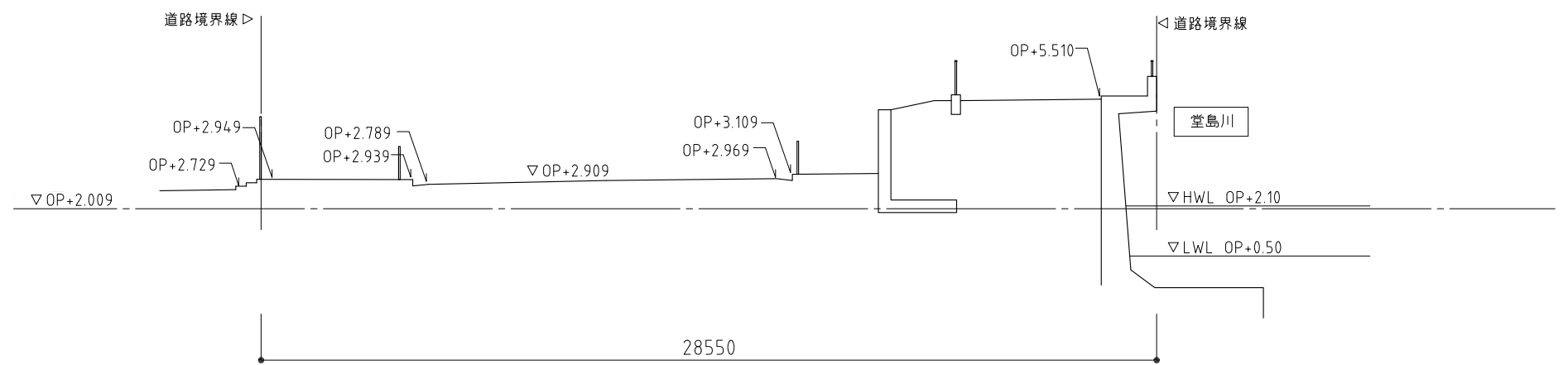

B部 1/200